

Screen Enclosure Profiles

Loxreen METALSOURCE®

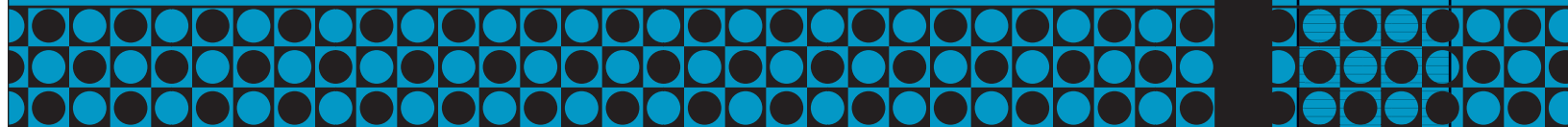

Screen Enclosure Profiles

INDEX

AA006167	5
AA008785	5
AA011508	5
AA015095	5
AA019026	1
AA019286	1
AA020203	3
AA020769	2
AA020770	4
AA020771	4
AA020940	4
AA021073	1
AA021081	1
OA099000	1
OA099001	1
OA099002	2
OA099003	2
OA099004	2
OA099005	2
OA099006	2
OA099007	2
OA099008	2
OA099009	2
OA099010	3
OA099011	3
OA099012	3
OA099013	4
OA099014	4
OA099015	4
OA099016	5
OA099017	5
OA099018	5
OA099019	5
OP068804	3

Screen Enclosure Profiles

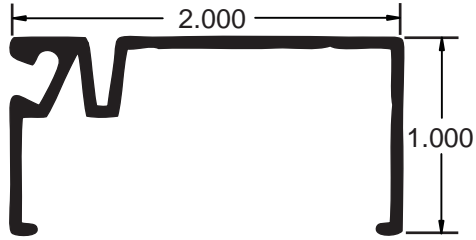

OA099000
1" x 2" Open Back w/ Kickplate Slot

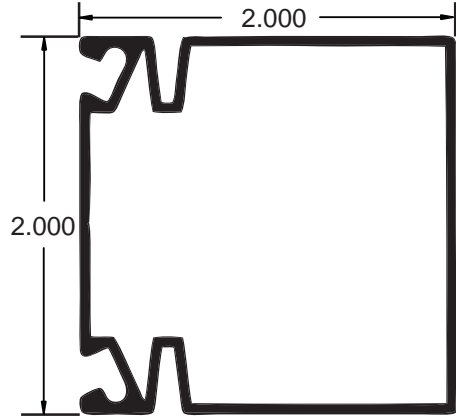

AA021081
2" x 2" Mainframe w/ Kickplate Notch

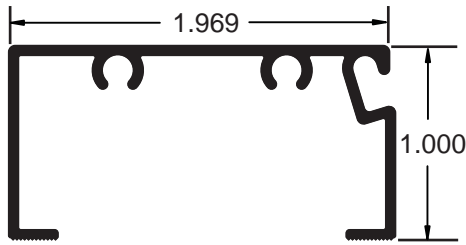

AA019286
1" x 2" Open Back

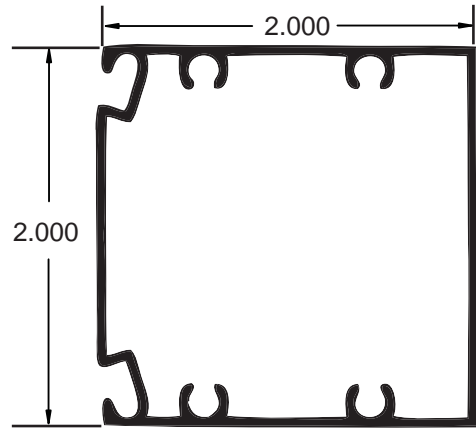

AA021073
2" x 2" Mainframe

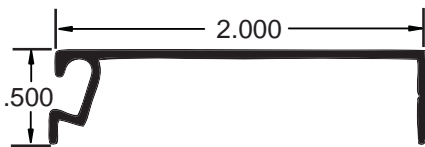

OA099001
1/2" x 2" Archway

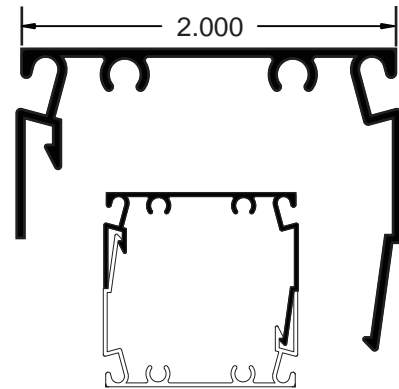

Shape mates with self

AA019026
2" Snap Post

Screen Enclosure Profiles

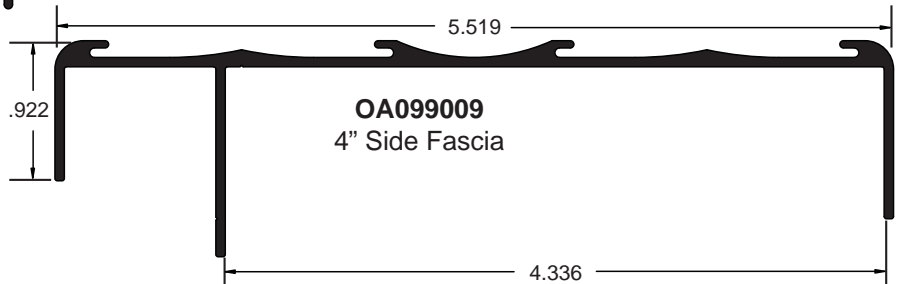
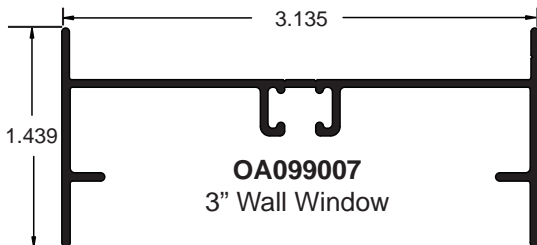
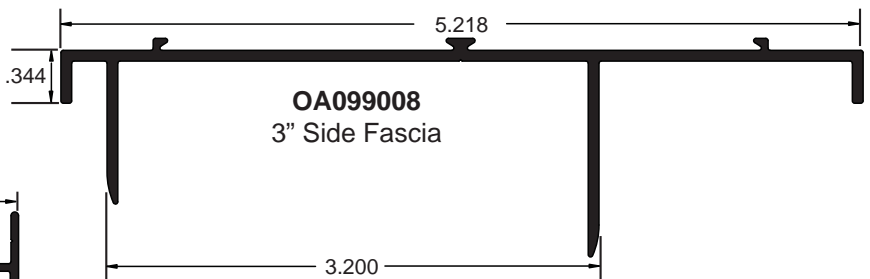
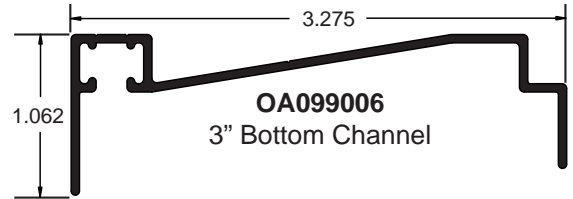
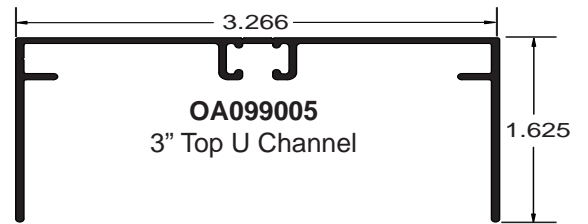
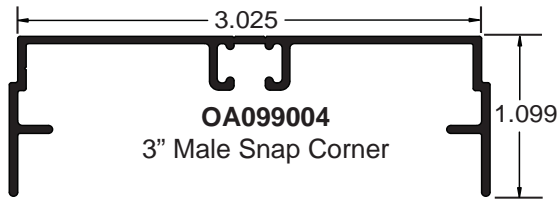
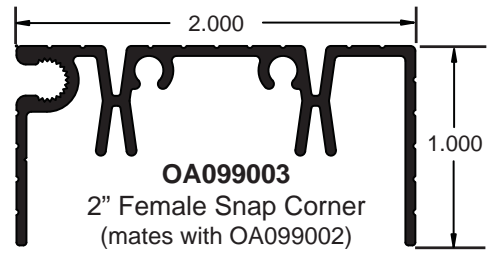
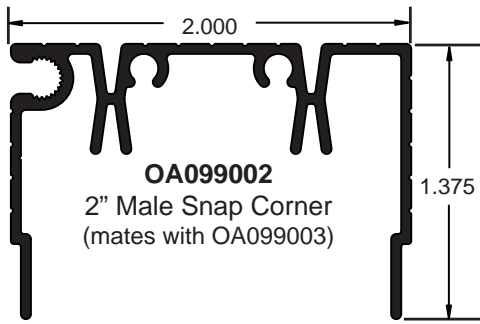

Screen Enclosure Profiles

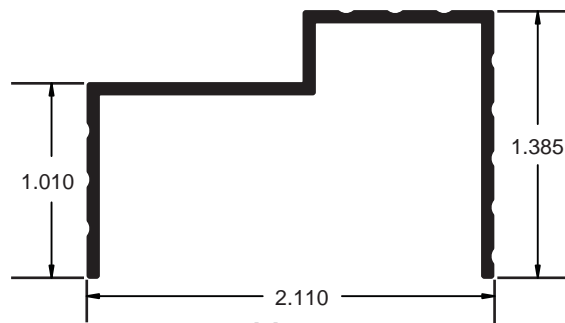
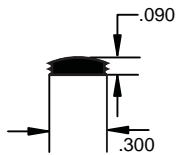
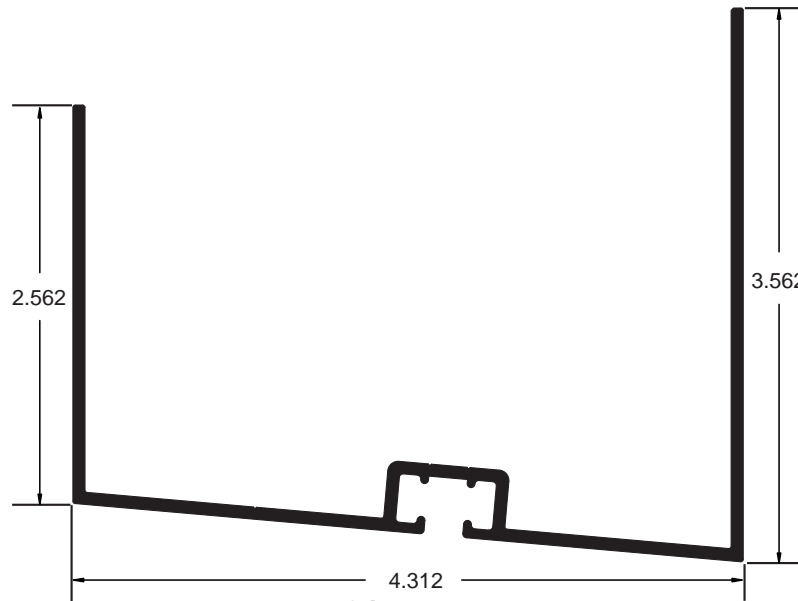
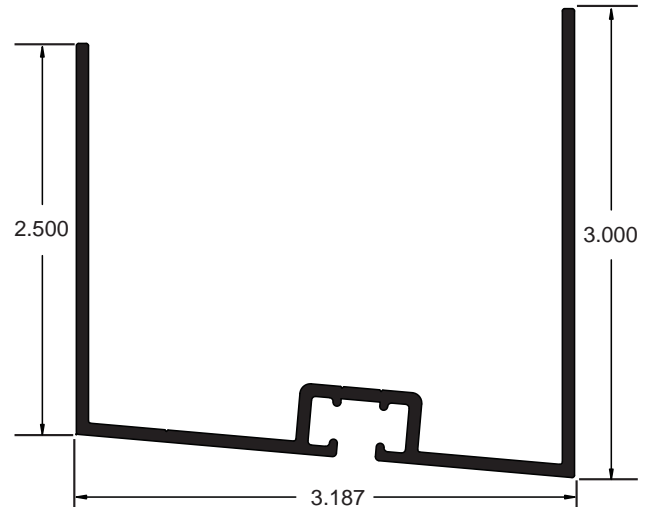
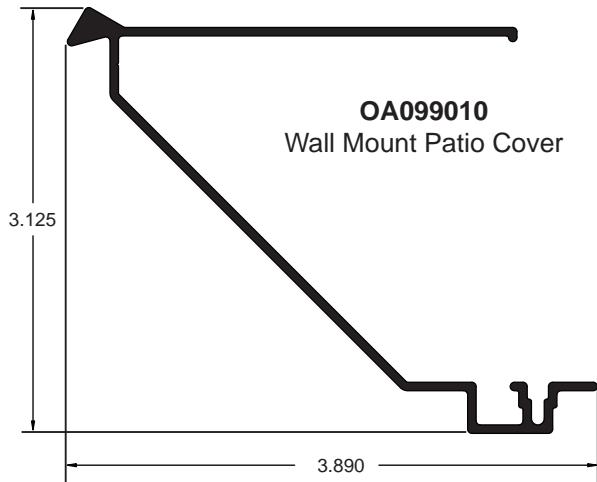

Screen Enclosure Profiles

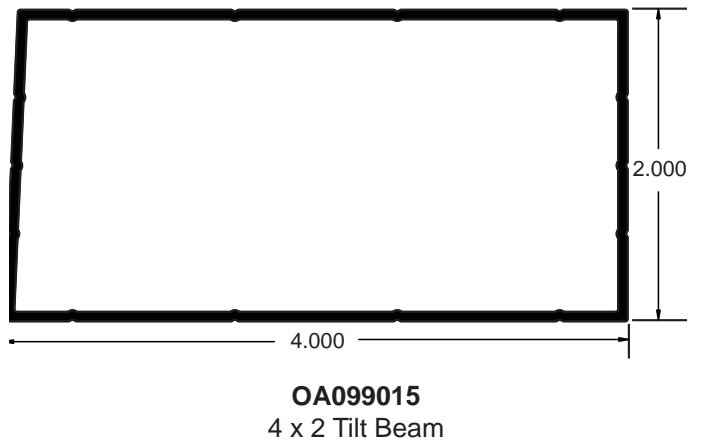
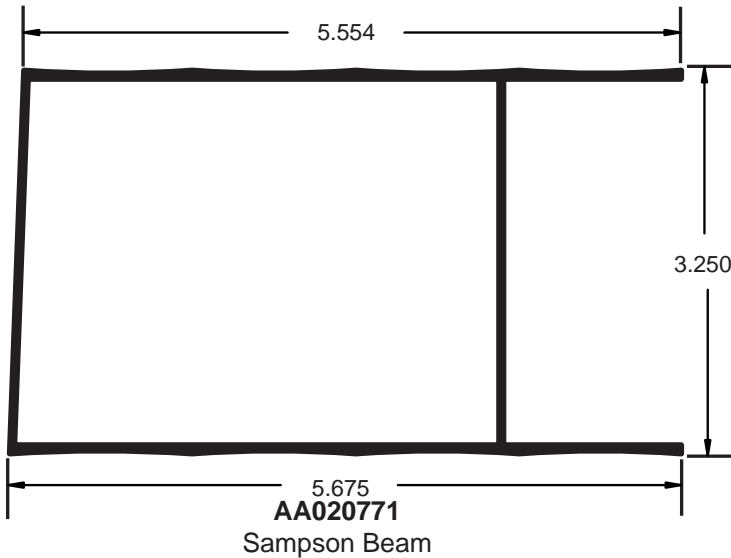
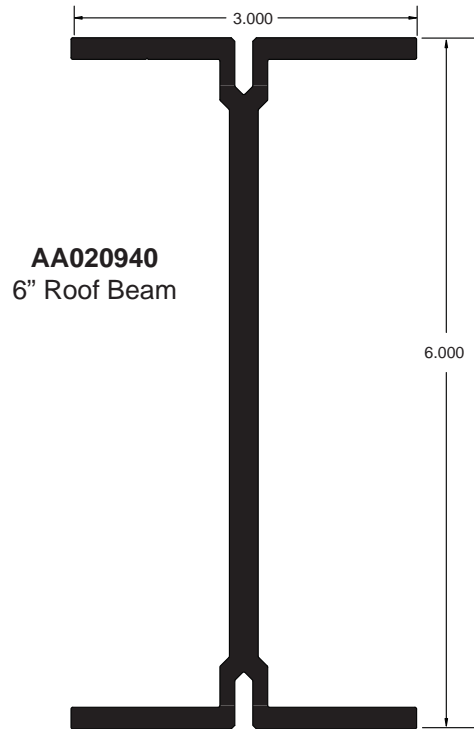
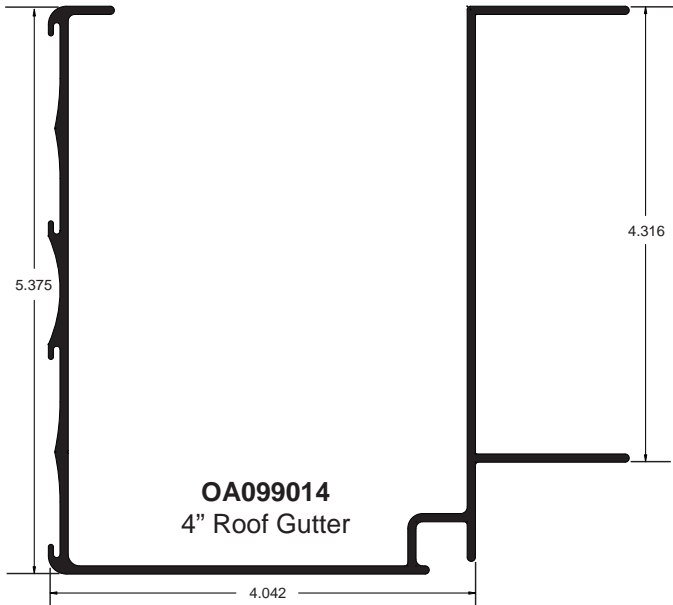
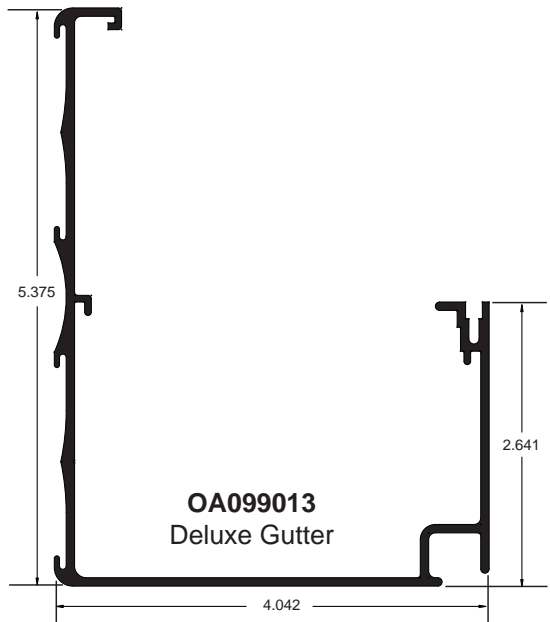
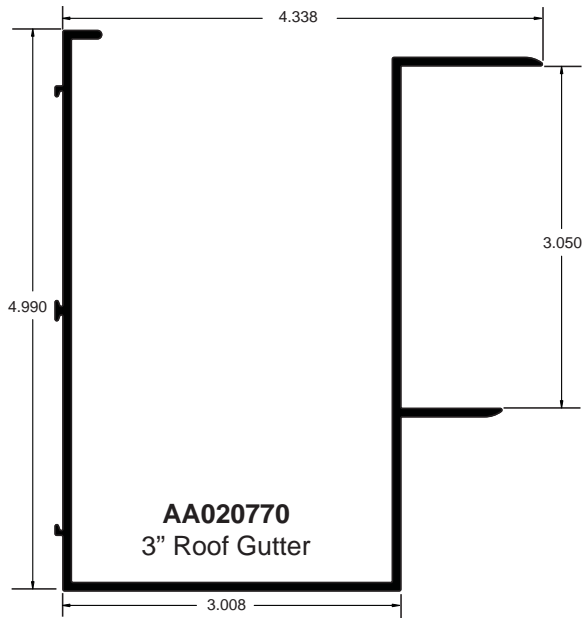

Screen Enclosure Profiles

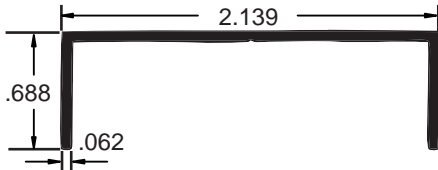

OA099016
2.015" x .688" x .062" Channel

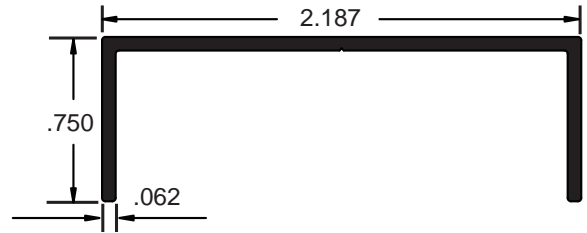

OA099018
2.187" x .75" x .062" U Channel

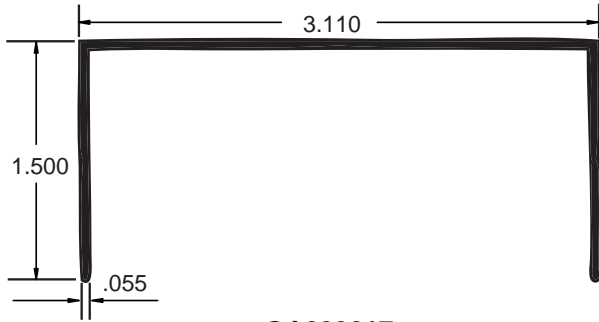

OA099017
3" x 1.5" x .055" Channel

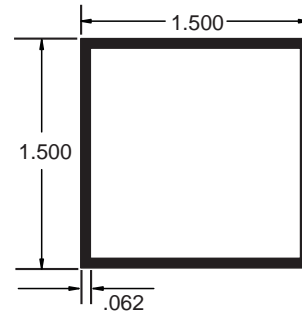

AA011508
1.5" x 1.5" x .062" Tube

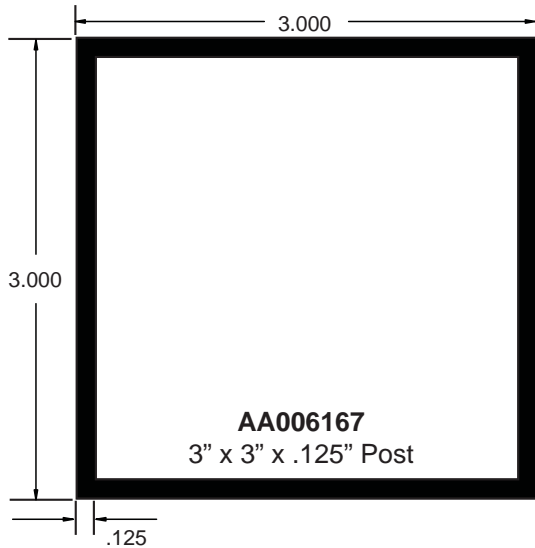

AA006167
3" x 3" x .125" Post

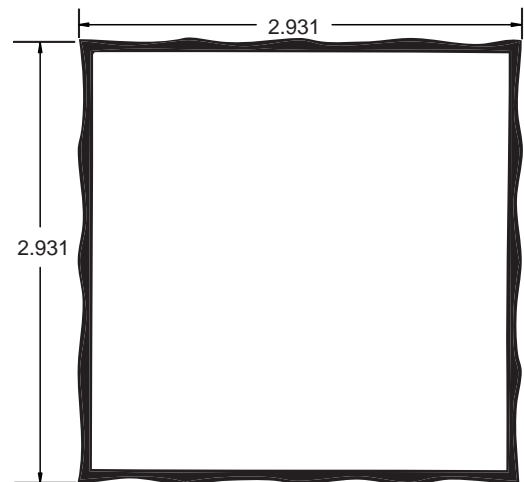

OA099019
3" x 3" x .078" Fluted Post

AA015095
3" x 3" x .103" Tube

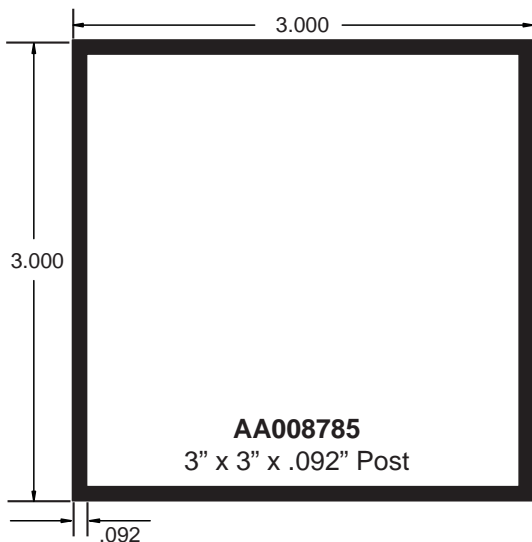

AA008785
3" x 3" x .092" Post

Miscellaneous Items

(Parts not stocked at all locations.)

OP068801**	Screen Door with 8" KP 36 x 80
OP068802**	Closure kit with adapter
OP068803**	Adjustable Z-bar
OP068804BK1000	Flat spline BK 1000' roll
OP068805**	Hinge
OP068806**	1 x 1 angle clip
OP068807**	In-swing latch kit

**All products available in Bronze (BZ) and White (WH) except spline.

Terms & Conditions

1. CONTRACT BETWEEN BUYER AND SELLER: A written order and acknowledgment shall constitute the contract between Buyer and Seller, and said Contract may not be amended or rescinded except by written agreement by both parties, referring expressly to this contract.

2. WARRANTY: Seller warrants that merchandise sold to Buyer shall be free from defects in material and workmanship and shall conform to specifications. **EXCEPT FOR SUCH WARRANTY, THE SELLER DISCLAIMS ANY AND ALL OTHER WARRANTIES OF ANY KIND WHATSOEVER, INCLUDING WITHOUT LIMITATION, ANY WARRANTY OF MERCHANTABILITY OR FITNESS FOR PARTICULAR PURPOSE AND INCLUDING BUT NOT LIMITED TO ANY ORAL OR WRITTEN DESCRIPTION OF THE PRODUCTS, THEIR CHARACTERISTICS OR PROPERTIES OTHER THAN THAT SPECIFICALLY STATED IN THE FOREGOING LIMITED WARRANTY. SELLER SHALL HAVE NO LIABILITY FOR CONSEQUENTIAL OR INCIDENTAL DAMAGES AS A RESULT OF THE SALE OF ITS MERCHANDISE.** In the event that its merchandise is not as warranted, Buyer's sole remedy will be, at Seller's election, replacement of the merchandise or return of the purchase price. Prior written approval from the Seller must be secured before returning any merchandise for credit.

3. TOLERANCES: Standard Commercial tolerances apply unless otherwise specified.

4. PRICE: Prices are based on existing conditions and are subject to change, at our discretion, at any time prior to order shipment. Unless otherwise specified, all prices are based on quantity shipped per release, with Buyer accepting over-run or under-run on each individual item based on standard shipping tolerances. Exact control of quantity shipped must be specified as a requirement of said contract.

5. CREDIT: All shipments shall be subject to the approval of Seller's Credit Department. If, in the sole judgment of the Seller, the financial responsibility of the Buyer is unsatisfactory, or becomes impaired, or if Buyer fails to make any payment in accordance with the terms of the contract, then Seller may defer or decline to make any shipments except upon receipt of satisfactory security or cash payments in advance, or Seller may terminate the contract.

6. TAXES: All prices are subject to the net additions of all Federal, State, or Municipal taxes or charges which may be established or levied upon or assessed against the merchandise under contract.

7. SHIPMENTS: Unless otherwise specified, title to all merchandise, and the risk of loss, shall pass to the Buyer upon delivery by the Seller to the transportation carrier at the shipping point or the actual transfer of possession to the Buyer, whichever is earlier.

8. DELAYS: Seller cannot be held liable for loss or damage arising from delay in fulfilling or failure to fulfill any accepted order in accordance with its terms where such delay or failure is caused by shortage of materials, delays of carriers, embargoes, fires, floods, strikes, riots, wars, acts of God, or other causes beyond our control.

9. RETURNED MATERIAL AUTHORIZATION: Seller must be notified within 10 days after delivery of Buyer's request to return merchandise. Upon receipt of Seller's authorization, merchandise must be returned within 30 days in accordance with Seller's shipping instructions. Merchandise must be returned in exactly the same condition as in which it was received by Buyer. Handling and restocking fees will be charged to Buyer's account.

10. CANCELLATION: Said contract is subject to cancellation only upon Seller's acceptance of such cancellation in writing and the effective date of cancellation shall be the date of such acceptance. Payment of cancellation charges shall be made by Buyer upon receipt of statement of same. Cancellation charges shall not exceed the purchase price of the canceled portion of the contract.

11. EQUIPMENT: Any equipment (including jigs, process dies and tools, etc.) which Seller constructs or acquires specifically for use on Buyer's order shall be the sole property of Seller, whether or not they are charged to Buyer's account. Die charges are for exclusive use of extrusion tooling and are not subject to refund. Dies which indicate no activity for two years or more will be scrapped without notice and replacement cost will be for Buyer's account.

12. PATENT PROTECTION: Seller agrees to indemnify Buyer against any claims or liabilities for or by reason of alleged patent infringement arising from the manufacture or sale of any merchandise furnished Buyer hereunder, except where the specifications, process, design or method of manufacture originated with Buyer, in which event Buyer agrees to indemnify Seller in like manner.

THE *Loxcreen* COMPANY, INC.

Contact our Service Center near you for more information.

Corporate Office

1630 Old Dunbar Road / PO Box 4004 (29171) / West Columbia, South Carolina 29172
(803) 822-8200 / FAX (803) 822-8547
www.loxcreen.com

Loxcreen MetalSource®

TEXAS

400 N. Great SW Parkway / Arlington, Texas 76011 / Metro 640-4456
All other areas (817) 649-2771 / FAX (817) 649-1760 / 800-222-4629

MISSOURI

PO Box 528 / 800 South Pemiscot Street / Hayti, MO 63851 / (573) 359-2811 / FAX (573) 359-2814
800-323-8314

OHIO

100 Westheimer Drive / Middletown, Ohio 45044 / (513) 539-2255 / FAX (513) 539-2288
800-432-4672

SOUTH CAROLINA

PO Box 4004 / West Columbia, SC 29171 / 1630 Old Dunbar Road / West Columbia, SC 29172
(803) 822-1600 / FAX (803) 822-8070 / 800-845-0840
Customer Service location
2300 Old Durham Road / Roxboro, North Carolina 27573 / FAX (336) 597-8821 / 800-682-9586

SOME ITEMS MAY NOT BE CARRIED IN STOCK.
PRICES ARE AVAILABLE UPON REQUEST.